

GT440 HYBRID

Mobile HSI Plant

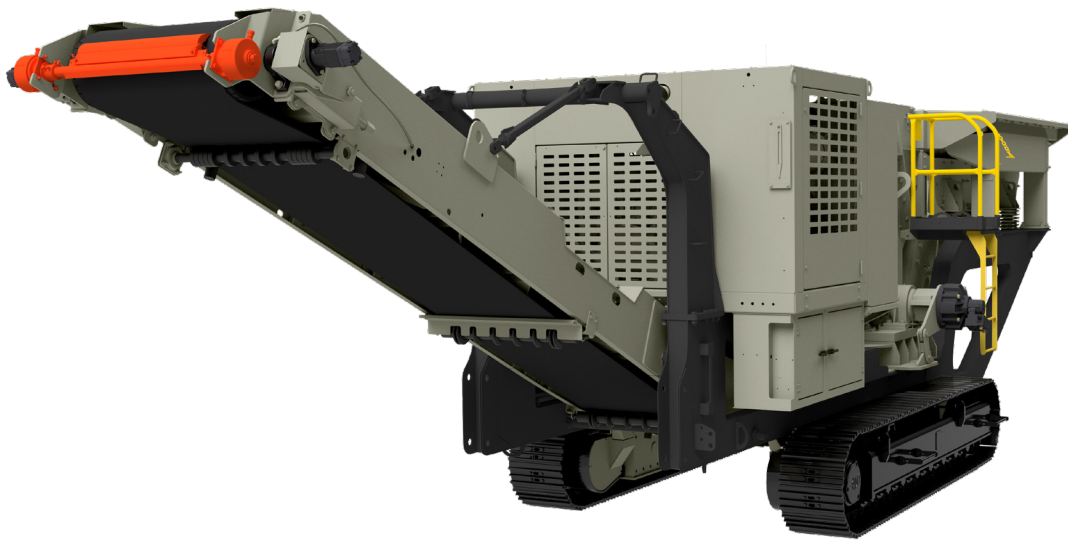

Vibrating Grizzly Feeder

- 40" (1016mm) x 14' (4.3m) Vibrating Pan Feeder
- 6 cubic yard hopper
- 43" step deck grizzly fingers 1" nominal spacing
- Bypass chute with flop gate and AR liner

Impact Crusher - Horizontal Shaft Impactor

- HSI opening height - 36" (914mm) HSI width - 40" (1,270mm)
- 3 bar MPR rotor with 402 lb. blow bars
- Multiple blow bar chemistries available to fit application
- Two (2) fully lined aprons
- Minimum apron settings - primary 2", secondary 1"
- Hydraulic adjustment
- RPM maximums vary on application and rotor
- Hydraulically actuated rear access

Under Crusher Conveyor

- 36" (900mm) fixed height with full spill boards
- Impact bed, 360PIW 2 ply
- Easily removed for maintenance

Chassis

- Sculpted frame design
- 15.7" (400mm) tracks with dual drive
- Diesel / Hydraulic track drive
- Balanced for zero cribbing
- Dust suppression with manifold

Hybrid Power Unit

- CAT C9.3B 380hp / 285kw Tier 4 Final
- 140gal / 520L fuel tank
- 135gal / 511 oil reservoir
- 380hp electric motor with starter, wiring, and switchgear; includes 400A main breaker for 480V 3ph 60 Hz power source
- Clutch and gearbox adapter for hydrostatic pump group

Controls

- Radio remote / tether control system
- OPS 7 with push button or touchscreen
- Crusher CSS adjusted safely at control panel
- Real time system monitoring display

Options

- 18" Side Delivery with hydraulic fold
- Permanent cross belt magnet
- Grizzly Bars with 2.5" spacing vs. grizzly fingers
- Grizzly Pre-Screener with 1/2" spacing
- 4 bar rotor (with 2 up, 2 down) vs. std.
- Lighting package mounted on engine housing
- Return chute for recirculation from off plant, optional flop gate and extension)
- Engine enclosure filter kit

Physical/Operating Characteristics

Dimension	Standard	Metric
Operating Length	51' 1"	15.6 m
Operating Width	10' 0"	3.2 m
Travel Length	51' 1"	15.6 m
Operating Width (Return Chute)	13' 5"	3.4 m
Operating Height	11' 5"	3.5 m
Operating Width (add for Side Discharge)	3' 11"	1.2 m
Operating Height (with Return Chute)	12' 6"	3.8 m
Travel Width	10' 0"	3.2 m
Travel Height	11' 5"	3.5 m
Feed Height	13' 5"	3.4 m
Ground Clearance	11' 0"	0.3 m
Discharge Height	10' 4"	3.2 m
Side Discharge (optional)	5' 4"	1.6 m
Diesel Highest Estimated Decibel Level (Operating with No Material)	98dB at 25' 96dB at 40'	7.6 m 12.2 m
Elec. Highest Estimated Decibel (Operating with No Material)	90dB at 25' 86dB at 40'	7.6 m 12.2 m
Feeder & Hopper	11,010lb	4,995kg
Optional Magnet & Support	2,800lb	1,270kg
Total Weight	85,000lb	38,555kg
Optional Side Delivery	1,300lb	590kg
Under Crusher Conveyor	5,500lb	2,495kg
Optional Return Chute	540lb	245kg



GT440

Mobile HSI Plant



Vibrating Grizzly Feeder

- 40" (1,016mm) x 14' (4.3m) vibrating pan feeder
- 6 cubic yard hopper
- 43" step deck grizzly fingers 1" nominal spacing
- Bypass chute with flop gate and AR liner

Impact Crusher - Andreas HSI

- HSI opening height - 36" (914mm) HSI width - 40" (1,016mm)
- 3 bar MPR rotor
- Multiple blow bar chemistries available to fit application
- Two (2) fully lined aprons
- Minimum apron settings - primary 2", secondary 1"
- Hydraulic adjustment
- RPM maximums vary on application and rotor
- Hydraulically actuated rear access

Under Crusher Conveyor

- 36" (900mm) fixed height with full spill boards
- Impact bed, 360PIW, endless belting
- Easily removed for maintenance

Chassis

- Sculpted frame design
- 19.7" (500mm) tracks with dual drive
- Balanced for zero cribbing
- Dust suppression with manifold

Power Unit

- Cummins QSL9 380 hp/258kw Tier 4 Final
- 140gal/530L fuel tank
- 135gal/511 oil reservoir
- One 12 GPM and one 20 GPM hydraulic circuits for magnet, side delivery, or auxiliary
- Radio remote/tether control system
- OPS 7 with push button or touchscreen
- Crusher CSS adjusted safely at control panel
- Real time system monitoring display

Options

- 18" side delivery with hydraulic fold
- Permanent cross belt magnet
- Grizzly pre-screener with 3/4" spacing
- Grizzly bars with 2.5" spacing vs. grizzly fingers
- Lighting package mounted on engine housing
- Belt scale for under crusher conveyor
- Return chute for recirculation from off plant, optional flop gate and extension
- 4 bar rotor (with 2 up, 2 down) vs. std.
- 18" return conveyor for recirculation from off plant, hydraulically lowers for transport
- Hydraulics for screen package (less screen)
- 5' x 10' double deck screen with cross and under screen conveyor (requires hydraulic package)
- CAT C13 440hp Tier III vs. Tier IV (international)
- Engine enclosure filter kit

Physical/Operating Characteristics

Dimension	Standard	Metric
Operating Length	49' 0"	14.9m
Operating Width	10' 3"	3.1m
Operating Width w/ Discharge	14' 3"	4.3m
Operating Height	11' 5"	3.5m
Travel Width	10' 3"	3.1m
Feed Height	11' 3"	3.4m
Ground Clearance	8"	0.2m
Recirculating Feed (optional)	4' 9"	1.4m
Highest Estimated Decibel Level (Operating with No Material)	100dB @ 3' 70dB @ 200'	0.9m 61m
Discharge Height	10' 7"	3.2m
Side Discharge (optional)	6' 1"	1.8m
Total Weight	87,760lb	39.807kg
Optional Magnet	1,830lb	830kg
Under Crusher Conveyor	5,265lb	2,390kg
Optional Side Delivery	1,130lb	512kg
Feeder & Hopper	10,890lb	4,940kg

