

# GRADALL®

## XL 4300 V

### HYDRAULIC EXCAVATOR

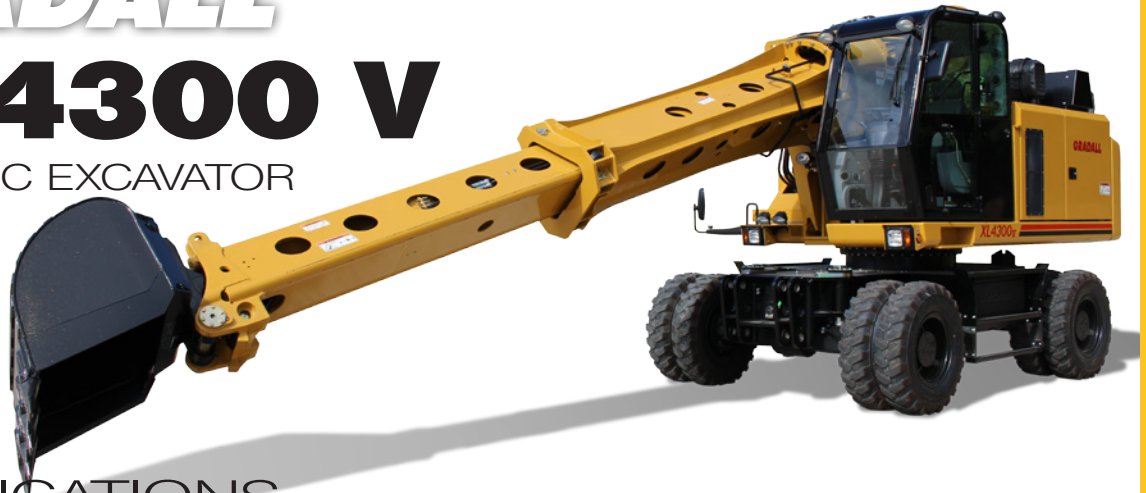

## SPECIFICATIONS

### Upperstructure Engine

VOLVO TAD571 VE, TIER 4f, 4 cycle, inline 4 cylinder, liquid cooled, electronic controlled. Vertical canister style lube filter attached to engine. Vertical canister style main fuel filter and fuel/water separation with manual feed pump attached to engine. Water in fuel indicator and alarm.

Gross Rating: 173HP @ 2200 RPM (129kW)  
590 ft lb Torque @ 1100-1500 RPM (800Nm)

Net Rating: 153 HP @ 2200 RPM (114kW)

Variable viscous fan clutch system. Vertical stacked hydraulic oil cooler, charge air cooler and radiator.

Maximum slope: 30°

24 volt starter, 100 amp alternator, two SAE #C31-S 1000 CCA batteries, two-stage air cleaner with high-efficiency pre-cleaner, vacuator valve and remote service indicator.

Fuel tank capacity: 99 gallons (375 L).

### Hydraulic System

#### PUMPS

One load-sensing, axial piston pump; oil flow 0-110 GPM (0-416 L/min).

Tandem gear pump (steering, brake/pilot) 10 GPM (38 L/min), 6 GPM (23 L/min).

#### SYSTEM MONITOR

Electronic monitor in cab indicates low hydraulic fluid level, high hydraulic fluid temperature, system working pressure, system pilot pressure.

#### SYSTEM SPECIFICATIONS

##### Six Cylinders

- 1 tool: 5.0" ID, 3.0" rod (127 mm x 76 mm), 25.9" (658 mm) stroke.
- 2 hoist: 4.25" ID, 3.15" rod (108 mm x 80 mm), 31.0" (787 mm) stroke.
- 1 telescope: 3.5" ID, 2.559" rod (89 mm x 65 mm), 12'6" (3.81 m) stroke.
- 2 single-acting axle oscillation cylinders: 4.528" ID, 4.528" rod (115 mm x 115 mm), 6.25" (159 mm) stroke.

### Three Hydraulic Motors

Swing, 64 hp (48 kW); tilt, 21 hp (16 kW); propel motor, 113 hp (84 kW).

#### Operating Pressures:

Hoist.....	4,900 psi	(331 BAR)
Tilt.....	2,500 psi	(172 BAR)
Swing.....	4,200 psi	(290 BAR)
Tool.....	4,900 psi	(331 BAR)
Telescope.....	4,900 psi	(331 BAR)
Propel.....	4,900 psi	(331 BAR)
Pilot System.....	550 psi	(38 BAR)
Braking & Steering.....	2,400 psi	(165 BAR)
Blade & Stabilizers.....	4,000 psi	(207 BAR)

#### Oil Capacity

Reservoir system 65 gallons (246 L). Pressurized reservoir with visual oil level gauges.

#### Filtration System

10 micron return filter, 10 micron pilot filter.

Fin and tube-type oil cooler with thermal by-pass and relief valves.

Pressure-compensated, load-sensing valves with circuit reliefs in all circuits.

### Operator Cab

All-weather cab with tinted safety glass windows, skylight, acoustical lining, four-way adjustable operator's seat, AM/FM radio, filtered fresh air heater, defroster and A/C. Front window slides to overhead storage. Rearview mirrors on right and left sides. Standard equipment includes operator's seat belt, windshield wiper and washer, high/low beam headlights, parking lights, brake lights, 4-way hazard lights, turn indicator lights, work lights and swing lights.

### Controls

Two electronic joysticks (hoist and bucket, telescope and swing), one rocker switch (tilt) control upperstructure. Joysticks mounted on arm pods, independently adjustable for individual operator comfort and convenience. Quick change joystick pattern switch located on instrument panel. Joysticks are self-centering; when controls are released, power for movement disengages and swing and tilt brake set automatically.

A tilting/telescoping steering column provides smooth, comfortable steering. Hydraulic foot pedal controls braking functions, giving smooth performance with infinite control. Travel speed is regulated with an electronic foot pedal control. A switch on the FWD/REV selector provides 1st/2nd gear selection. Independent rocker switches control stabilizers, axle oscillation, park brake and hazard lights. Another switch on the column provides marker lights, high/low headlights and direction indicators.

#### Engine Controls and Instrumentation

Key operated ignition/starter switch, throttle and main battery disconnect switch. Air cleaner condition indicator. Electronic monitor indicates fuel level, low battery charge, lube oil pressure, high coolant temperature, engine rpm and engine hours. Fuel saving auto idle feature sends engine rpm to idle when control circuits are in neutral for seven seconds.

### Swing

Priority swing circuit with axial piston motor. Planetary transmission.

Swing speed: 7.0 RPM.

#### Swing Brake

Automatic spring-set/hydraulic release wet disc parking brake. Dynamic braking is provided by the hydraulic system.

## Undercarriage

A full-time 4-wheel drive transfer case delivers power from the hydraulic drive motor to the drive axles. Both axles are equipped with internal wet-disc type service brakes. The steering axle is fitted with oscillation lock cylinders. Optional stabilizer arms provide a solid digging platform for increased stability. A blade attachment for finish grading (as shown) is one of many options available for specific applications.

**Tires:** 10.00 x 20 Super-Lug.

**Axles:** ZF Model 3070 (FTF 2090).

**Transmission:** ZF Model HL 290.

**Drive Motor:** Rexroth A6 Series, 160cc/Rev.

**Minimum Turning Radius:** 25'5" (7.75 m).

## Undercarriage Drive

Variable displacement high torque piston motor powers the 2-speed power shift transmission. Speed mode selection can also be done while moving. Electronically operated travel alarm signals excavator movement.

Travel speed on flat, level surface—mph (km/hr):

	Creeper Mode	Standard Mode
<b>First Gear</b>	1.4 mph (2.2 kmh)	4.6 mph (7.4 kmh)
<b>Second Gear</b>	5.5 mph (8.9 kmh)	17.5 mph (28.2 kmh)

## Weight

Approximate working weight with 36" (914 mm) excavating bucket, fuel tank half full.  
43,580 lb (19,768 kg)  
Outriggers = 2,720 lb (1,234 kg)  
Blade = 1,529 lb (694 kg)

**Rated Bucket Breakout Force:**  
25,405 lb (113 kN).

**Rated Boom Force:** 22,075 lb (98.2 kN).

## GRADALL Model XL 4300 V Excavator Rated Lift Capacity - LB (KG)

LOAD POINT HEIGHT		LOAD RADIUS										
		10' 0" (3.0 m)		15' 0" (4.6 m)		20' 0" (6.1 m)		25' 0" (7.6 m)		Maximum Radius	Over End	Over Side
		Over End	Over Side	Over End	Over Side	Over End	Over Side	Over End	Over Side			
Above Ground Level	20' 0" (6.1 m)									23' 4" (7.1 m)	4980 (2260)	4980 (2260)
	15' 0" (4.6 m)			10160 (4610)	10160 (4610)	7115 (3225)	7115 (3225)	5200 (2360)	5200 (2360)	25' 9" (7.9 m)	4970 (2255)	4970 (2255)
	10' 0" (3.0 m)			12020 (5450)	12020 (5450)	8015 (3335)	7790 (3535)	5715 (2590)	5565 (2525)	27' 0" (8.2 m)	5045 (2290)	4880 (2215)
	BOOM LEVEL 8' 6" (2.6 m)			12375 (5615)	12375 (5615)	8190 (3715)	7935 (3600)	5820 (2640)	5530 (2510)	27' 2" (8.3 m)	5080 (2305)	4800 (2175)
	5' 0" (1.5 m)			12540 (5690)	12150 (5510)	8195 (3715)	7790 (3535)	5760 (2615)	5445 (2470)	27' 2" (8.3 m)	5005 (2270)	4715 (2140)
At Ground Level				11190 (5075)	11190 (5075)	7945 (3605)	7570 (3435)	5630 (2555)	5310 (2410)	26' 5" (8.1 m)	5140 (2330)	4840 (2195)
Below Ground Level	5' 0" (1.5 m)	10180 (4620)	10180 (4620)	8990 (4080)	8990 (4080)	7000 (3175)	7000 (3175)			24' 7" (7.5 m)	5495 (2490)	5340 (2420)
	15' 0" (4.6 m)	6710 (3045)	6710 (3045)	6905 (3130)	6905 (3130)	5870 (2665)	5870 (2665)			21' 3" (6.5 m)	5580 (2530)	5580 (2530)
	10' 0" (3.0 m)	4470 (2030)	4470 (2030)	5220 (2370)	5220 (2370)					15' 6" (4.6 m)	5205 (2360)	5205 (2360)

**NOTE:** The above loads are in compliance with the SAE standard J1097 DEC2005. They do not exceed 87% of hydraulic lifting capacity or 75% of tipping capacity.

Loads shown in shaded areas indicate the load is limited by tipping rather than hydraulic lift capacity.

The rated lift capacity is based on the machine being equipped with 8,800 lb (4,014 kg) counterweight, standard boom, standard tires, no auxiliary hydraulics and no bucket.

Adjust the listed rated capacities by subtracting the value listed for bucket/attachment used:

8065-6007 60" (1.5 m)	Ditching -	807 lbs (366 kg)
8065-6006 66" (1.7 m)	Ditching -	892 lbs (405 kg)
8065-6118 72" (1.6 m)	Ditching -	1148 lbs (521 kg)
8045-6020 24" (610 mm)	Excavating -	603 lbs (274 kg)
8045-6020 30" (762 mm)	Excavating -	660 lbs (300 kg)
8045-6022 36" (914 mm)	Excavating -	741 lbs (336 kg)
8045-6023 42" (1.1 m)	Excavating -	841 lbs (382 kg)
8065-6117 48" (1.5 m)	Excavating -	959 lbs (435 kg)
8065-6013 72" (1.8 m)	Dredging -	1114 lbs (505 kg)
8065-6102 40" (1.0 m)	Pavement -	1262 lbs (573 kg)
8065-6024 8" (2.4 m)	Blade -	630 lbs (285 kg)
8065-6009 Single Tooth	Ripper -	557 lbs (253 kg)

**NOTE:** Bucket adjustment values are 87% of the actual bucket weights.

The load point is located on the bucket pivot point, including loads listed for maximum radius.

Do not attempt to lift or hold any load greater than these rated values at specified load radii and heights. The weight of slings and any auxiliary devices must be deducted from the rated load to determine the net load that may be lifted.

**ATTENTION:** All rated loads are based on the machine being stationary and level on a firm supporting surface. The user must make allowance for particular job conditions such as soft or uneven ground, out of level conditions, side loads, hazardous conditions, experience of personnel, etc. The operator and other personnel must read and understand the operator manual before operating this machine. Rules for safe operation of equipment must be adhered to at all times.

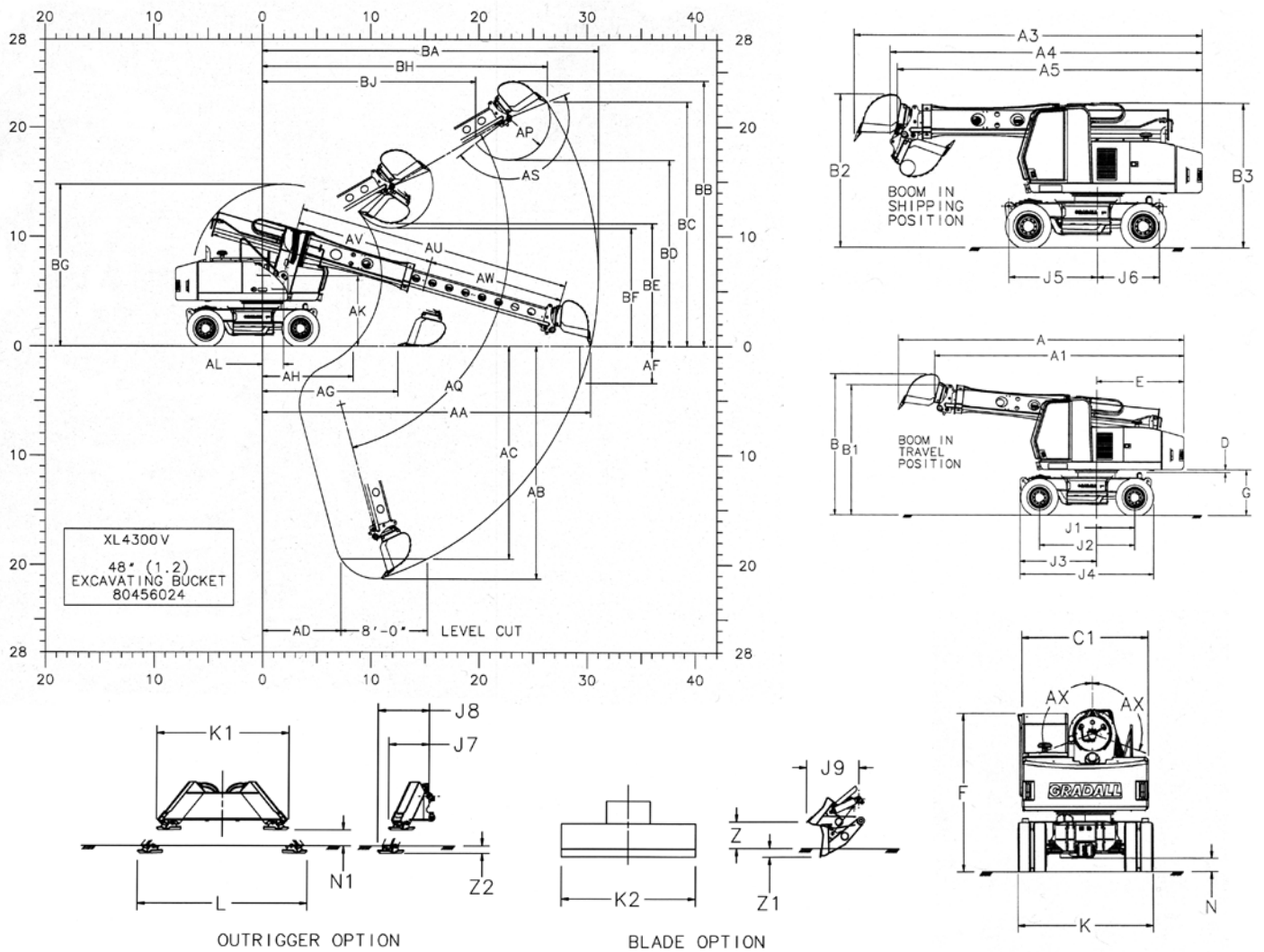

## Dimensions

- A** Overall length with bucket open (travel position): 26'3" (8.0)
- A1** Overall length without bucket (travel position): 22'11" (7.0)
- A3** Overall length with bucket open (shipment position): 26'6" (8.1)
- A4** Overall length with bucket closed (shipment position): 23'9" (7.2)
- A5** Overall length without bucket (shipment position): 23'3" (7.1)
- B** Overall height with bucket open (travel position): 12'10" (3.9)
- B1** Overall height without bucket (travel position): 11'10" (3.6)
- B2** Overall height with bucket open (shipment position): 11'6" (3.5)
- B3** Overall height without bucket (shipment position): 10'11" (3.3)
- C1** Width of upperstructure: 8'6" (2.6)
- D** Minimum clearance, upperstructure to undercarriage: 3" (78 mm)
- E** Swing clearance, rear of upperstructure: 8'0" (2.4)
- F** Top of cab to groundline: 10'7" (3.2)
- G** Clearance, upperstructure to groundline: 4'2" (1.3)
- J1** Axis of rotation to centerline of fixed axle: 3'6" (1.1)
- J2** Wheelbase of undercarriage: 8'9" (2.7)
- J3** Axis of rotation to front of undercarriage: 7'0" (2.1)
- J4** Nominal overall length of undercarriage: 12'3" (3.7)
- J5** Axis of rotation to front option attachment pin: 6'9" (2.1)
- J6** Axis of rotation to rear option attachment pin: 4'9" (1.4)
- J7** Outrigger length, attachment pin to pad in up position: 2'7" (0.8)
- J8** Outrigger length, attachment pin to pad in down position: 3'3" (1.0)
- J9** Blade length, attachment pin across blade in up position: 34" (1.0)
- K** Overall width undercarriage: 9'1" (2.8)
- K1** Overall width outrigger (up position): 8'4" (2.5)
- K2** Overall width blade: 9'0" (2.7)
- L** Overall width outrigger (down position): 10'8" (3.3)
- N** Ground clearance (per SAE J1234): 11" (275 mm)
- N1** Ground clearance (outrigger option): 12" (300 mm)
- Z** Blade above ground (option): 1'8" (505 mm)
- Z1** Depth below ground level of blade (option): 7" (166 mm)
- Z2** Depth below ground level of outrigger (option): 6" (142 mm)
- AA** Maximum radius at groundline: 30'4" (9.2)
- AB** Maximum digging depth: 21'3" (6.5)
- AC** Maximum depth for 8' level cut: 19'6" (5.9)
- AD** Minimum radius for 8' level cut at depth "AC": 7'3" (2.2)
- AF** Maximum depth of vertical wall which can be excavated: 3'5" (1.0)
- AG** Minimum level cut radius with bucket flat on groundline: 12'6" (3.8)
- AH** Minimum radius at groundline: 8'4" (2.5)
- AK** Boom pivot to groundline: 6'5" (2.0)
- AL** Boom pivot to axis of rotation: 1'11" (585 mm)
- AP** Bucket tooth radius: 3'10" (1.2)
- AQ** Boom pivot angle: 30° Up and 75° Down
- AS** Bucket pivot angle: 165°
- AU** Maximum telescoping boom length (boom pivot to bucket pivot): 25'3" (7.7)
- AV** Minimum telescoping boom length (boom pivot to bucket pivot): 12'9" (3.9)
- AW** Telescoping boom travel: 12'6" (3.8)
- AX** Bucket tilt angle (both sides of center): 110°
- BA** Maximum radius of working equipment: 31'0" (9.5)
- BB** Maximum height of working equipment: 24'2" (7.4)
- BC** Maximum bucket tooth height: 22'4" (6.8)
- BD** Minimum clearance of bucket teeth with bucket pivot at maximum height: 17'0" (5.2)
- BE** Minimum clearance of fully curled bucket at maximum boom height: 11'2" (3.4)
- BF** Minimum clearance of bucket teeth at maximum boom height: 10'9" (3.3)
- BG** Maximum height of working equipment with bucket below groundline: 14'9" (4.5)
- BH** Radius of bucket teeth at maximum height: 26'4" (8.0)
- BJ** Minimum radius of bucket teeth at maximum bucket pivot height: 19'8" (6.0)

Metric units are meters (m) unless noted.  
Machines shown may have optional equipment.

## Optional Equipment

Vandalism protection kit including window covers.

Strobe light.

Block heater.

ROPS protective cab.

Auxiliary Hydraulics - Additional hosing and piping for hydraulic powered attachments. [Maximum pressure 4900 psi (331 BAR) Maximum flow 30 GPM (114 L/min)].

## Attachments

Quick change and reversible buckets fabricated of steel plate, with high strength, low alloy cutting edges and wear strips. Standard attachments available for wide range of applications. Capacities shown are in heaped cu. yd.



Part No.	Width	Capacity (Cu. yd.)	Capacity (m³)
8045-6020	24" (610 mm)	3/8	0.31
8045-6021	30" (762 mm)	1/2	0.41
8045-6022	36" (914 mm)	5/8	0.54
8045-6023	42" (1.07 m)	3/4	0.64
8045-6024	48" (1.22 m)	1	0.76

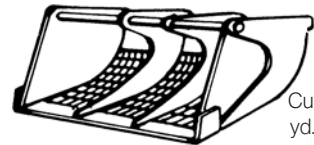

Part No.	Width	Capacity (Cu. yd.)	Capacity (m³)
8065-6013	72" (1.83 m)	1 1/8	0.87

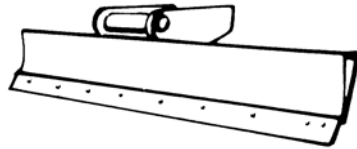

8065-6024 8' (2.4 m) Grading blade

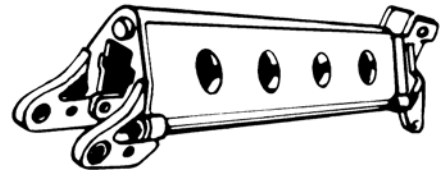

8065-5028 4' (1.2 m) Boom extension  
8065-5029 6' (1.8 m) Boom extension  
8065-5030 8' (2.4 m) Boom extension



Part No.	Width	Capacity (Cu. yd.)	Capacity (m³)
8065-6104	15" (381 mm)	1/5	0.15
8065-6012	21" (533 mm)	1/4	0.19

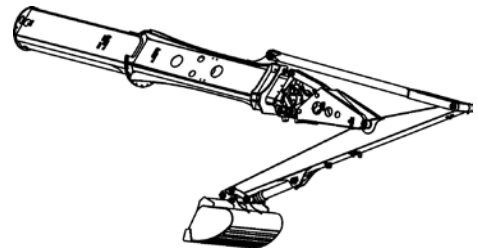

8075-5045 Telestick attachment

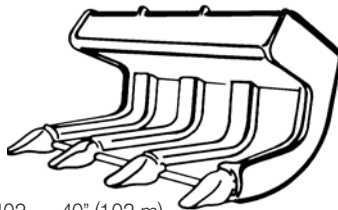

8065-6102	40" (1.02 m)		
8065-6115	18" (0.457 m)		
8065-6116	24" (0.610 m)		
8065-6114	28" (0.711 m)		

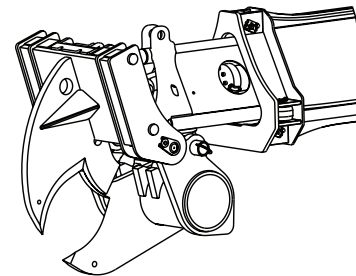

8045-5052 Tree Limb shear attachment

It is Gradall Policy to continually improve its products. Therefore designs, materials and specifications are subject to change without notice and without incurring any liability on units already sold. Units shown may have optional equipment.

# GRADALL®

406 Mill Ave. SW, New Philadelphia, Ohio 44663  
Phone: 330-339-2211 Fax: 330-339-8468  
www.Gradall.com

Certified ISO 9001



Form No. 11633 9/16  
Printed in USA

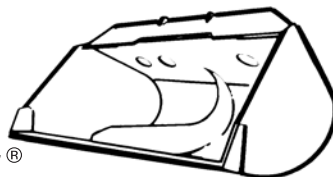

Part No.	Width	Capacity (Cu. yd.)	Capacity (m³)
8065-6040	30" (0.762 m)	3/8	0.3
8065-6007	60" (1.52 m)	7/8	0.73
8065-6006	66" (1.68 m)	1	0.76
8065-6002	72" (1.83 m)	1 1/8	0.87

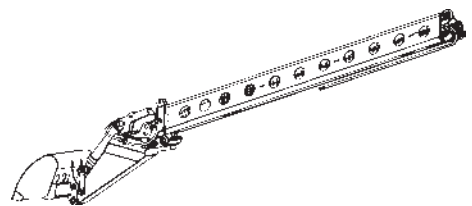

8075-5034 7' (2.1 m) Live boom

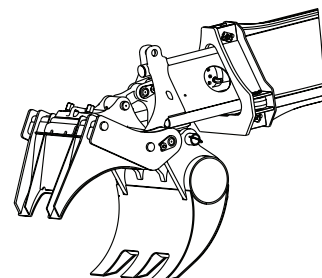

8075-5023 Fixed thumb grapple