

2 TON ASPHALT HOT BOX AND RECYCLER

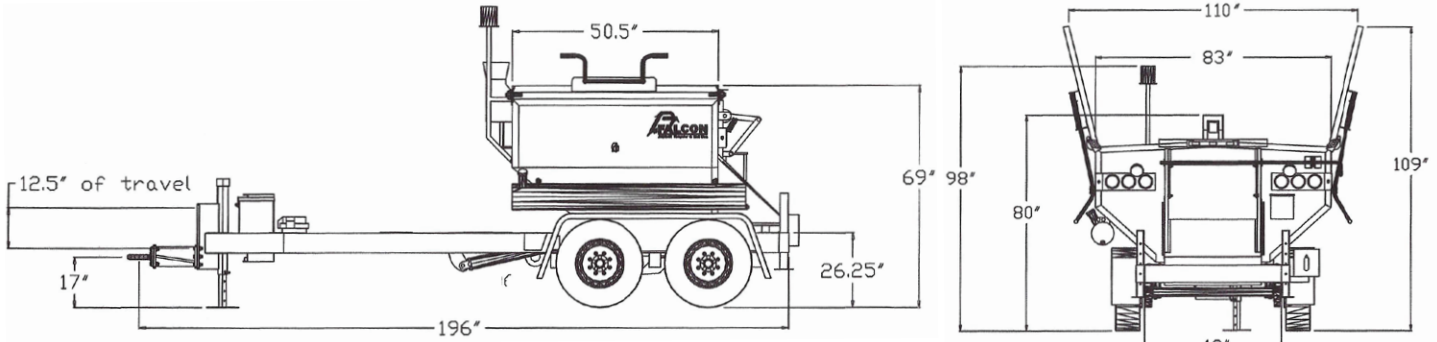

Type	2 Ton Trailer
Capacity	4,000 lbs of material
Base Weight	3,350 lbs
Weight loaded with material	7,350 lbs
GVWR	7,000 lbs (Dump box): 9,810 lbs
Fuel Source	Diesel
Fuel Capacity	15 gallons for dump box - 18 gallons on fixed trailer
Burner Type	105,000 BTU Diesel Beckett burner w/electronic spark ignite
Number of burners	1 (options for dual burner)
Unloading door	Insulated guillotine, 16"Hx33" W
Loading doors	Manual 50"L x 41"W
Hopper opening	110" - doors open
Width	83"
Length	16'
Height	69"
Construction	Triple wall insulated – air jacketed
	10 gauge capping channel and corner molding (adds structural integrity)
	Hopper floor heated – ¼" steel
	Wiring is external to hopper
Axles	Double eye leaf springs, Single axle - Tandem axle on dump box
Tires	8-bolt wheels w/9x14.5" tire upgrade option to 16" tires
Brakes	Electric brakes with safety breakaway
Hitch	2.5" pintle eye
Paint	Blasted and painted with two coats of epoxy primer and urethane finish
Frame	Tubular steel frame with boxed-in and enclosed gussets
Asphalt repair areas	9'x9'x4" depth (80 potholes 1'x1'x4" depth)
Warranty	Two year machine warranty, lifetime frame warranty

Falcon Asphalt Repair Equipment

2000 Austin Street
 Midland, MI 48642
 sales@falconrme.com

Phone: (989) 495-9332
 Fax: (989) 495-9342
 www.falconrme.com

WWW.FALCONRME.COM



2 TON ASPHALT HOT BOX AND RECYCLER

STANDARD:

- Battery charger package
- Automatic temperature control
- VIP technology
- One piece ceramic combustion chamber (diesel)
- Diamond tread plate hopper access platform
- Heated shoveling platform
- 12 volt deep cycle batteries
- Conspicuity tape

OPTIONS:

- Hydraulic dump function
- Dual burner recycling package
- Hydraulic loading and unloading doors
- LED light upgrades including LED arrow board
- 30 gallon tack tank with spray system and hose reel
- Basket for mounting compactor
- Wash-down system
- 24-hour or 7-day timer
- Short frame - 14'
- XL frame - 18', 20'
- Electric overnight heat
- Hoist - manual or electric
- Tire upgrade
- Propane torch with bracket
- Other customizable options available

Falcon hot boxes and recyclers give you unparalleled **versatility**. You can **transport cold mix**, keeping it warm during the winter months and making it easier to work with; you can **transport hot mix and keep it hot all day**; and you can **hold hot mix overnight**, keeping it warm for up to 48 hours. You can also **reclaim unused hot mix**, eliminating the waste of good material, and you can **recycle asphalt chunks and millings**. All of this makes Falcon the most versatile machine you can buy for pavement preservation.

All Falcon machines are built with pride in Midland, Michigan and come with the following standard features: **patented heat management system** featuring a 5-year maintenance-free combustion chamber, **large unloading door** for easy access, **patented VIP system** to eliminate damage from low voltage, a **2-year machine warranty and lifetime frame warranty**, an emphasis on **curbside safety** and easy platform work surfaces, and a durable and **reliable dump system**.

THE FALCON ADVANTAGE



Large Unloading Door For Easy Access

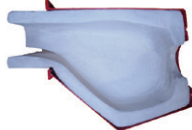

Patented Heat Management System



Platform For Safe, Easy Hopper Access



Patented VIP - Low Voltage Shutdown



Dump System - Pivot Point & V-Body



Lifetime Frame Warranty

Falcon Asphalt Repair Equipment

2000 Austin Street
Midland, MI 48642
sales@falconrme.com

Phone: (989) 495-9332
Fax: (989) 495-9342
www.falconrme.com

WWW.FALCONRME.COM